

**T-T Flow<sup>®</sup>  
Valves**

**Working with  
Air Valves**



T-T Flow Valves, Woore, Cheshire  
Tel: + 44 (0) 1630 647111 Fax: + 44 (0) 1630 642100  
[www.ttflow.com](http://www.ttflow.com)

**T-T PUMPS<sup>®</sup>** **T-T Pumping Stations<sup>®</sup>** **T-T Controls<sup>®</sup>** **T-T Service<sup>®</sup>** **T-T Agricultural & Environmental<sup>®</sup>** **T-T Flow<sup>®</sup> Valves**



With over 55 years' of experience, T-T Flow are professionals in the design, manufacture and distribution of a range of engineered waterworks valves and associated ancillary equipment to the water, process and allied industries. Globally continued commitment to product development, quality and response to feedback has maintained our position at the forefront of the market.

T-T Flow offers a large product selection for many applications. It is not limited to manual wedge gate valves, swing check valves and air valves, but extends to complete project packages incorporating actuated valves, fabricated operating equipment, pipework and ancillaries.

### **Design**

Designed in the UK, our in-house team of experienced engineers utilise the latest design software, continually re-evaluating products and materials to ensure that relevant international and regional standards and market requirements are met.

T-T Flow heavily invests in research and development and the highest production standards are achieved through considerable resource investment in the latest equipment and techniques, including finite element analysis. In-house test facilities allow for full product testing including pressure (both seat and body), mechanical and endurance.

### **Quality**

Quality is given the highest priority and the company has a continual programme of improvement. T-T Flow has approval of its quality management systems to ISO 9001. Furthermore, prior to leaving the company each product undergoes a comprehensive inspection ensuring the highest quality products arrive on site. Hydrostatic and electrical testing facilities are available in house.

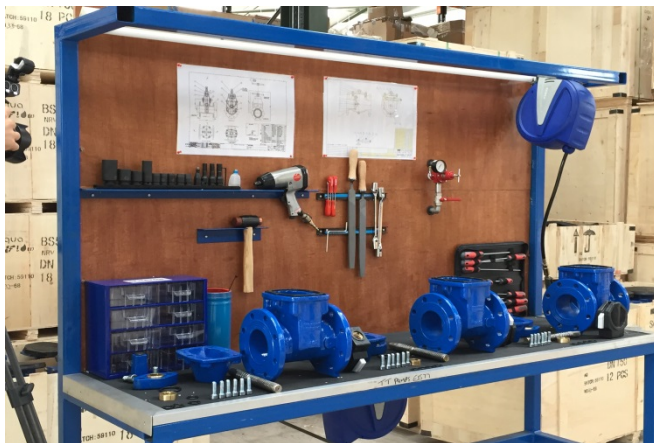

### What are the benefits of T-T Flow products and services?

- Unique product designs supported by third party approvals
- Many products designed and manufactured in the UK
- Technical advice from knowledgeable and approachable engineers
- Cost effective, customised and single sourced packages
- Fully equipped machine assembly shop
- In-house calibrated test facilities
- Supporting documentation, certification and CAD drawings
- Extensive stock of products offering same-day delivery to your site
- Comprehensive after-sales support

### Contents

Physics of the air	4
Air in the pipeline	5
The concept of critical velocity	7
Problems caused by air pockets	8
Air valves	10
RFP technology	12
AS technology	14
Application and sizing of air valves:	18
1-Accumulation of air pockets	18
2-Pipe burst analysis	19
3-Pipe drainage analysis	21
Allowable negative pressure	22
Air valve location	23

The purpose of this manual is to provide the fundamental aspects for engineers, designers and operators in order to understand the presence of air in pipeline systems, the problem related to it and how to size and use T-T Flow air valves for the proper protection of the system and cost reduction.

## Physics of the air



Air is a precious resource and a mixture of gas, it consists of about 78% nitrogen, 21% oxygen and then less than 1% of others like argon, water vapours and more.

The most important physical laws that can be applied in understanding air are the ideal gas law, and the Henry's law.

### The ideal gas law

The law, written as follows, relates pressure, temperature and volume expressing the equation of state and the behaviour of the majority of gases, like air, under many conditions with some exceptions out of the application for which this manual has been created and destined to.

This is written as follows:

$$p \cdot V = n \cdot R \cdot T$$

Where  $p$  is the pressure of the gas,  $V$  is the volume of the gas,  $n$  is the number of moles,  $R$  is the gas constant,  $T$  is the temperature. By  $n$  we define  $m/M$  where  $m$  is the mass and  $M$  is of course grams per mole.

In SI units  $p$  is expressed in Pascals,  $V$  is  $m^3$ ,  $n$  in moles and  $T$  in Kelvin.  $R$  has the value  $8,313 \text{ J}\cdot\text{K}^{-1}\cdot\text{mol}^{-1}$ .

### Henry's law

The Henry's law is needed to understand the dissolution of air inside the liquid (for our cases like water, wastewater) according to the variation in pressure stating that basically the solubility of a given gas is proportional to the partial pressure of the gas itself above the liquid.

In a mathematical expression this extremely important concept can be written like

$$p = Kc' \cdot c$$

Where  $p$  is the partial pressure of the gas,  $c$  is the molar concentration of the dissolved gas,  $Kc'$  is Henry's law constant on the molar concentration depending on the gas, liquid and temperature.

For the proper understanding and computation of air presence in water distribution and sewage system both laws, real gas and Henry's must be used.

Gas	constant atm/(mol/dm <sup>3</sup> )
He	2865,00
O <sub>2</sub>	756,70
N <sub>2</sub>	1600,00
H <sub>2</sub>	1228,00
CO <sub>2</sub>	29,76
NH <sub>3</sub>	56,90

The inverse of the Henry's law constant is the molar solubility of the gas. For example: the amount of oxygen dissolved in water under atmospheric condition at 25°C can be obtained by knowing its partial pressure (20,67 KPa in this case), then calculating the molar concentration and finally mass through the molar weight. If we do that the result is that for each litre of water we have 0,0089 g of oxygen and 0,0138 g of nitrogen whose sum makes 0,023 g of air which is almost the common 2%, used sometimes as an approximation for the required air release percentage through air valves versus the volume of water.

Table: molar Henry's law constants for aqueous solutions at 25°C.

## Air in the pipeline

For our purpose and scope the proper understanding of the air physical laws is important, because the amount of gas coming out of solution will be moving uncontrolled along the pipe, gathering in some points and creating many problems. Temperature and pressure will play a key role for this calculation.

**Temperature.** The solubility strongly affected by variations in temperature; the higher the temperature is, the lower the percentage of air dissolved is and therefore the higher the amount of air produced. Wastewater pressurised lines due to biological activities are without any doubt strongly involved with it and for that at risk. Talking about water supply lines, a pipeline above ground is definitely subject to a lot more temperature variations than a buried line, and for that more critical from this point of view, although the latter in case of high environmental temperatures and average digging depth will still be exposed to the problem.

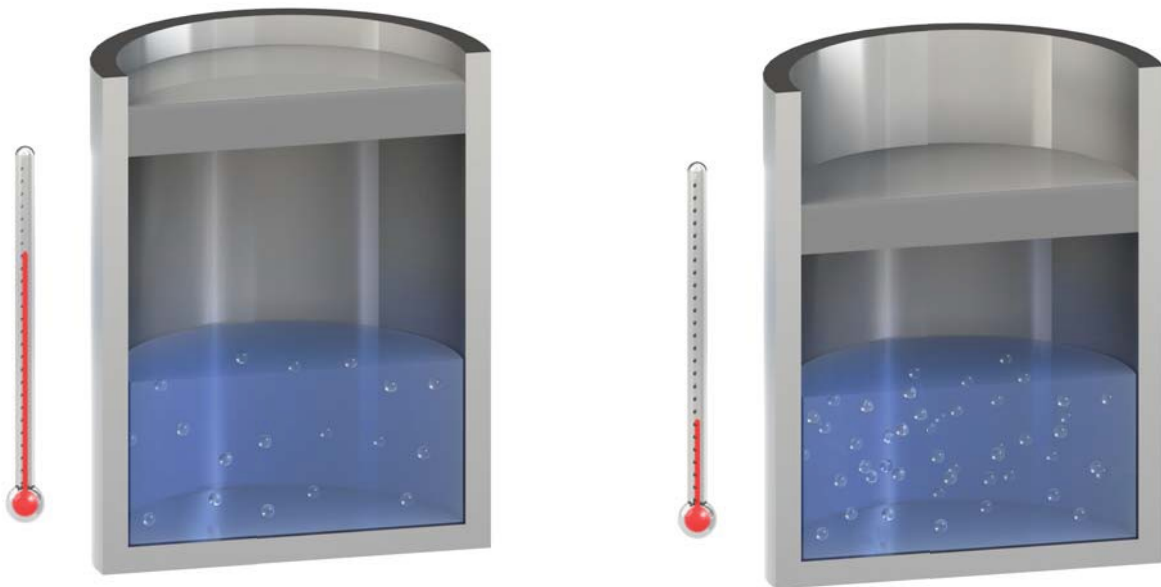

**Pressure.** Considering the effect of pressure variation on the solubility ratio it is important to remember that air dissolution is directly proportional to the pressure. Therefore, whenever we are in presence of minor and distributed head loss, producing a pressure drop like a PRV for example, air will be produced continuously. We can think of our systems, where pressure and temperature variations are unavoidable for the proper regulation and control, like uncontrolled and relentless air manufacturers.





In addition to variation in temperature and pressure the main reasons for the presence of air in pipeline systems are:

- air collection at the intake or outflow locations such as tanks, risers and open sources
- free outfall and on gravity supply lines
- air entrainment at the pumping station due to variation in level at the sump
- turbulence and vortices through the pumps impeller
- hydraulic jumps on descending slopes
- incomplete air discharge during pipe filling
- biological activity
- negative pressure during transients related to rapid variations in flow
- air valves jammed and without release capacity.

Once we acknowledge that air is constantly present and forming in our systems it is important to study how it moves along the pipeline which can occur with many flow patterns, divided on the shape and position of air pockets present on the stream.

For example for flat, or sort of pipes like picture 1, tests revealed air gathers under an elongated and thin form whose thickness, if the volume increases, remains constant. Increasing slope, see picture 2, the air shape will change dramatically becoming more and more like a wedge; in this case an increase of the quantity of air would produce an increase in thickness and length of the pocket.

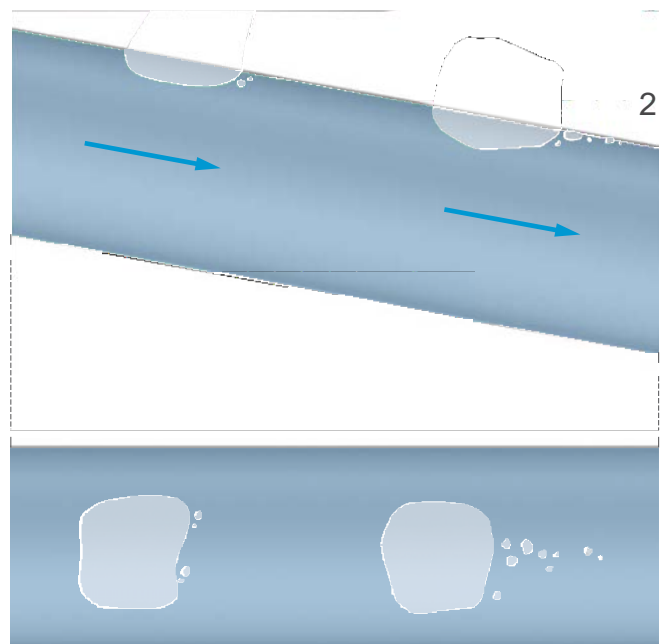
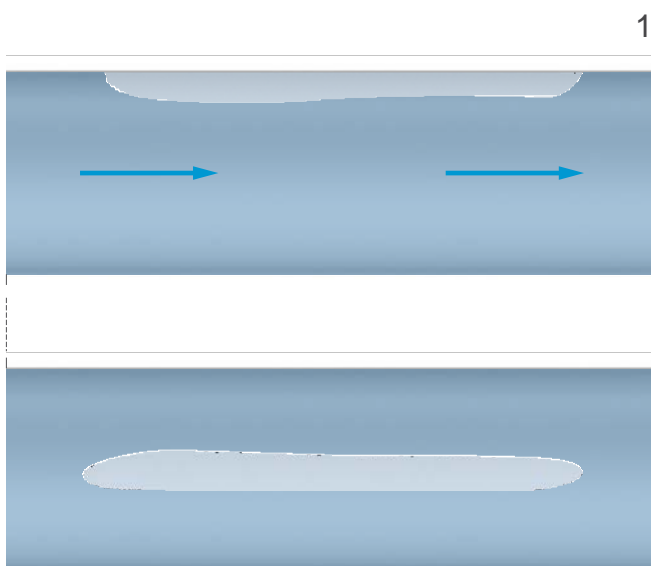

Although this has been studied of many years additional research is still needed through advanced numerical tools and field experiments. The equations and physics to calculate it are rather complex, involving drag, pipe DN and slope, buoyancy, viscosity, friction, surface tension and many more, not part of the scope of this manual.

## The concept of critical velocity

As long as we are in presence of ascending slopes (ref. picture 1) the resultant of the main forces acting on the air pocket will inevitably push it upwards with the flow, problems may arise in case of high points, descents and changes in slope descending. For such critical points the most important element is a procedure to determine whether the velocity of the fluid is enough to move air pockets downstream, this value ( $V_c$ ) also known as critical velocity expressed through the following formula:

$$\frac{V_c}{(g \cdot D)^{0,5}} = S_f \cdot [0,56 \cdot (\sin S)^{0,5} + a]$$

Where  $g$  is the acceleration of gravity,

$D$  is the pipe DN,

$S_f$  is a safety factor depending on the pipe material and slope,

$S$  is the slope,

$a$  is a non-dimensional parameter with a range between approximately 0,42 and 0,64 which is a function of acceleration of gravity, pipe DN, and the volume of the air pockets.

The applicability of the equation includes downward slopes up to approximately 40°, above which the critical velocity is actually reducing as a consequence of the lower friction of the air against the pipe wall.

$$\frac{V_c}{(g \cdot D)^{0,5}} = 0,33$$

Where  $g$  is the acceleration of gravity,

$D$  pipe DN.

Whenever the flow profile changes from supercritical to subcritical hydraulic jumps will occur. In pipeline they can be found in downwards slopes (ref. picture 2) and near changes in slope (ref. picture 3) in absence of air valves and where large pockets are presents, involving turbulence and pumping air into the pipe flowstream.

The Froude number plays a key role for the understanding of this concept.

$$F_r = Q \cdot B^{0,5} / (A^{1,5} \cdot g^{0,5})$$

Where  $A$  is the wet cross section,

$Q$  is the flow,

$B$  is the width,

$g$  is the acceleration of gravity.

The amount of air produced is:

$$Q_{air} / Q = 0,0025 \cdot (F_r - 1)^{1,8}$$

In systems with substantial variation of the flow rate during the day, like some waste water applications but even treated water, the fluid flow is not able to absorb and carry downstream the amount of air pumped from the hydraulic jump, with possible blow back effects and dangerous movement of large air pockets and fluid section upstream.

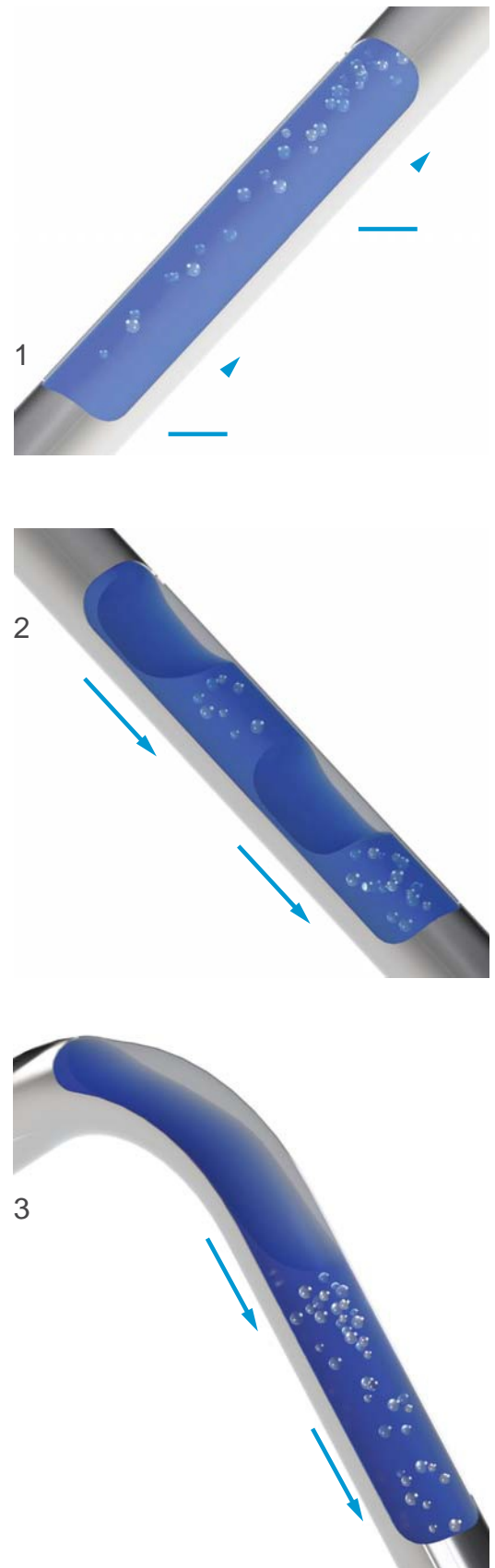

## Problems caused by air pockets

The presence of air pockets in our systems is definitely an undesired condition, associated with many problems such as:

- Reduction in flow capacity, because basically air gathers in some points behaving like a series of gate valves closing gradually;
- Corrosion, applicable to metallic pipes like steel, ductile cast iron for example, triggered by the presence of air under pressure in contact with the wet wall of the pipe;
- Wrong flow measurements and readings caused by the excessive presence of air inside the pipe and consequent variation in density.

If we don't use air valves, air pockets accumulate up to a certain volume to split up and move when an unbalance of forces is created, namely the drag force produced by the flow, friction produced by the pipe roughness, surface tension and buoyancy. When that happens sudden movement of mass of fluid will generate unwanted surge and pressure variations propagating along the system.

The example shows a gravity line with a plastic pipe with ID of about 375 mm, 7,3 Km long with a design capacity of 240 m<sup>3</sup>/h. Due to the accumulation of air pockets on the highlighted segments having a gradient steeper than HGL and requiring a high velocity for air removal, the measured flow was actually 200 m<sup>3</sup>/h.

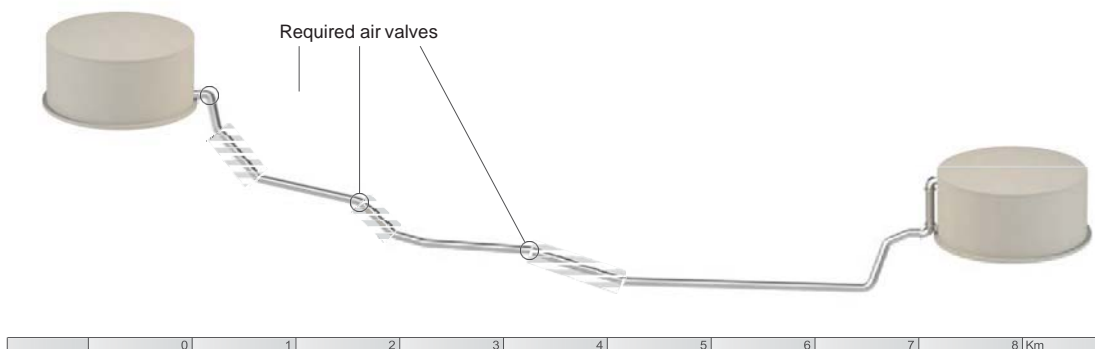

In case of pumping systems, for example, due to the presence of air a higher pressure head is needed to overcome head loss created by the air pockets, with inevitable increase in energy consumption and maintenance as pumps are working out of their best efficiency point.

The gauge power, also called  $P_h$  and expressed in KW, is equal to:

$$P_h = H_t \cdot Q \cdot \nu \cdot g / 1000$$

Where  $H_t$  is the total pumping head,

$Q$  is the flow (m<sup>3</sup>/s),

$\nu$  is the specific weight of water (Kg/m<sup>3</sup>),

$g$  is the acceleration of gravity (m/s<sup>2</sup>).

The second example shows a pumping system with a plastic pipe with ID of approximately 130 mm, 2,7 Km long. With a design capacity of 42 m<sup>3</sup>/h, due to the presence of air pockets produced by biochemical gas, a sump level excessively low and frequent pump cycles then accumulated on the underpass, the measured dropped to a staggering value of 8 m<sup>3</sup>/h. One air valve only was located at the high point without any positive result for the problem. The solution was the proper adjustment of the shut-off level on the pump pit, the introduction of air valves at the pump, upstream and downstream the underpass in addition to anti-surge protection systems to reduce pressure fluctuations.

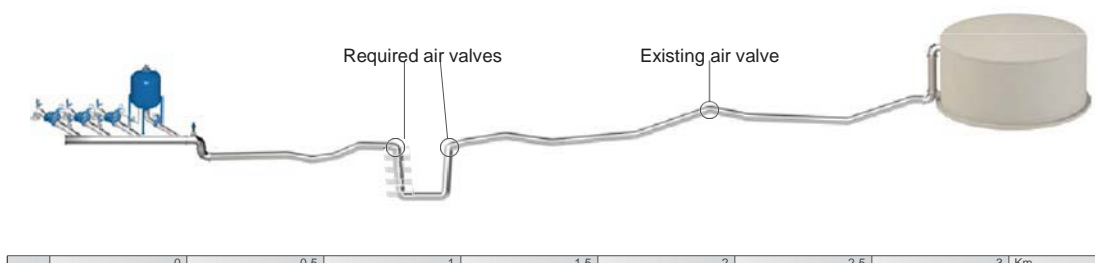



### Pumping system without air valves

On pumping systems the absence of air valves will increase the  $H_t$  and therefore the overall cost as much as, sometimes, substantial values like 30% of the average operating cost. The effect is a huge amount of money wasted during the year to cover for that loss, with a value usually much bigger than the expected cost to install air valves.

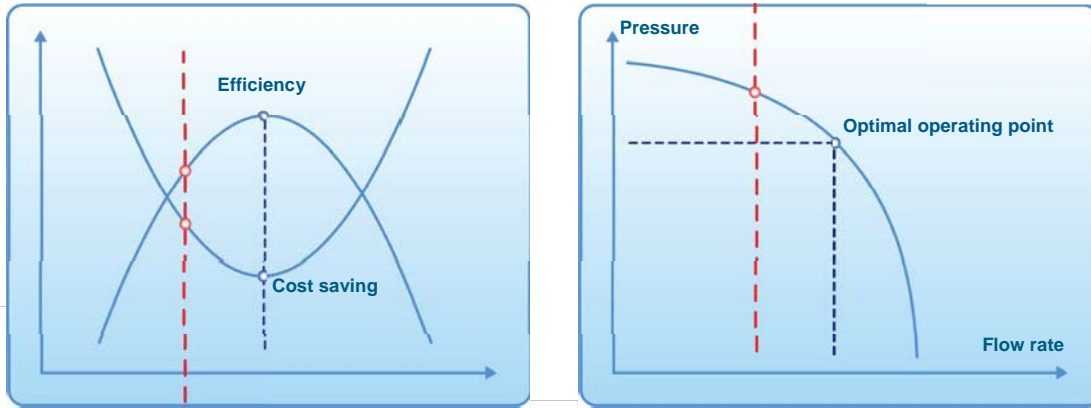

### Pumping systems with air valves

The proper use and location of air valves will ensure the right flow according to the design requirement, with a dramatic reduction of operating costs in terms of energy and pumps maintenance, thanks to the increase of the overall efficiency.

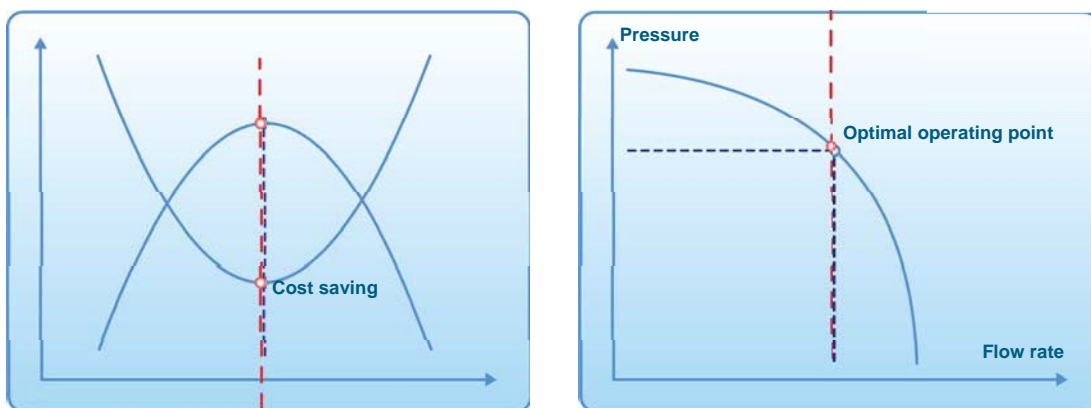

## Air valves

### Air release



This kind of air valve, also called single effect or one function, will ensure the air release of air pockets accumulated during working conditions through the nozzle only, whose size depends on the application and the nominal pressure. The corresponding T-T Flow Model would be the Aquabrake Mini.



### Air vacuum valves

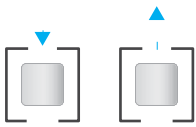

This valve, also known sometimes as single orifice or vacuum breaker, allows for the entrance and discharge of large volumes of air during pipe draining and filling operations without any sort of automatic air release function or nozzle. The air vacuum valves are therefore not recommended, except for specific applications, for their inability to get rid of air pockets that may accumulate and gather at their locations. For T-T Flow the equivalent model would be the 2F, applicable to the entire range.

### Combination air valves

This valve, also known sometimes as double orifice or triple functions, allows for the entrance and discharge of large volumes of air during pipe draining and filling operations in addition to the air release of air pockets in working conditions. Combination air valves in general, with T-T Flow corresponding to Aquabrake, are most of the time not suitable for the job because likely to generate water hammer during rapid closures of the float as explained in the next pages of this manual.



### The old double chamber concept

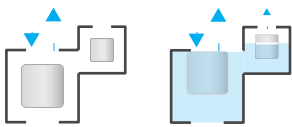

Combination air valves were invented hundreds of years ago with a double chamber technology, where basically two separate floats of different size, housed in two chambers, would perform the functions required. This old concept, still visible today on the market, is usually associated with problems like premature closure of the float during air outflow and inflow, float deformation and jamming, reduced capacity and excessive size and weight.

### The single chamber solution

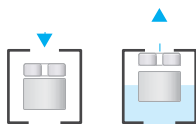

Instead of the floats being located into two separated chambers within a single chamber combination air valve, they overlap each other, generating one single mobile block. They still have the two orifices for air release and the passage of large volumes of air. However, this time in one body with a great improvement in terms of air flow performances, water tightness and accuracy, also thanks to the choice of special materials for the internals and innovative technical solutions for the whole assembly.

### Combination surge prevention air valves

This valve, also known sometimes as non-slam, surge arrestor, anti-shock, allows for the entrance and of large volumes of air during pipe draining in addition to the air release of air pockets in working conditions. Depending on the technology and solution adopted by the manufacturers the air outflow will be controlled to avoid abrupt closures of the internal floating systems with consequent water hammer sometimes devastating for the entire system. Two kinds of surge prevention technologies have been developed: RFP and AS. These are explained in the next pages of the manual that eventually became the standard for the majority of the applications instead of conventional combination air valves.

In the process of studying and understanding air valves we don't have to forget that the product is handling two elements at the same time, air and water, whose properties and behaviours are totally different.

It is estimated that 40% of pipeline bursts occur during pipe filling either caused by the absence or undersized air valves, or due to air valves properly chosen and located along the profile but exposed to uncontrolled and rapid approach of the water column and consequent water hammer. The reason is mainly related to the significant difference of values in terms of density and compressibility between air and water, with a ratio being respectively 800:1 and 20000 to 1.

Because water has high density (approximately 1000 kg/m<sup>3</sup>) pipelines carry a huge amount of mass, momentum and kinetic energy. Assuming a pipe with area of 1 m<sup>2</sup> and length of 1000 m with a velocity of 2 m/s the kinetic energy would be  $\frac{1}{2}mv^2$  and equal to approximately 2.000.000 J. This is more or less the same amount of energy of a truck falling from a 30-story building.

In addition to kinetic energy a liquid pipeline typically transports large amount of mass and momentum as well, as instance for the above mentioned case study we would have 2000000 kg m/s momentum, implying that large forces are generated for variation in flow such as a rapid closure of the air valve

To grasp this concept we have to imagine air being discharged through the air valve at high velocities causing a rapid acceleration of the incoming waterfront, when the latter arrives to the air valve. The float is raised up to the closed position and fluid is suddenly brought to a stop, creating upsurges sometimes fatal for the system itself.

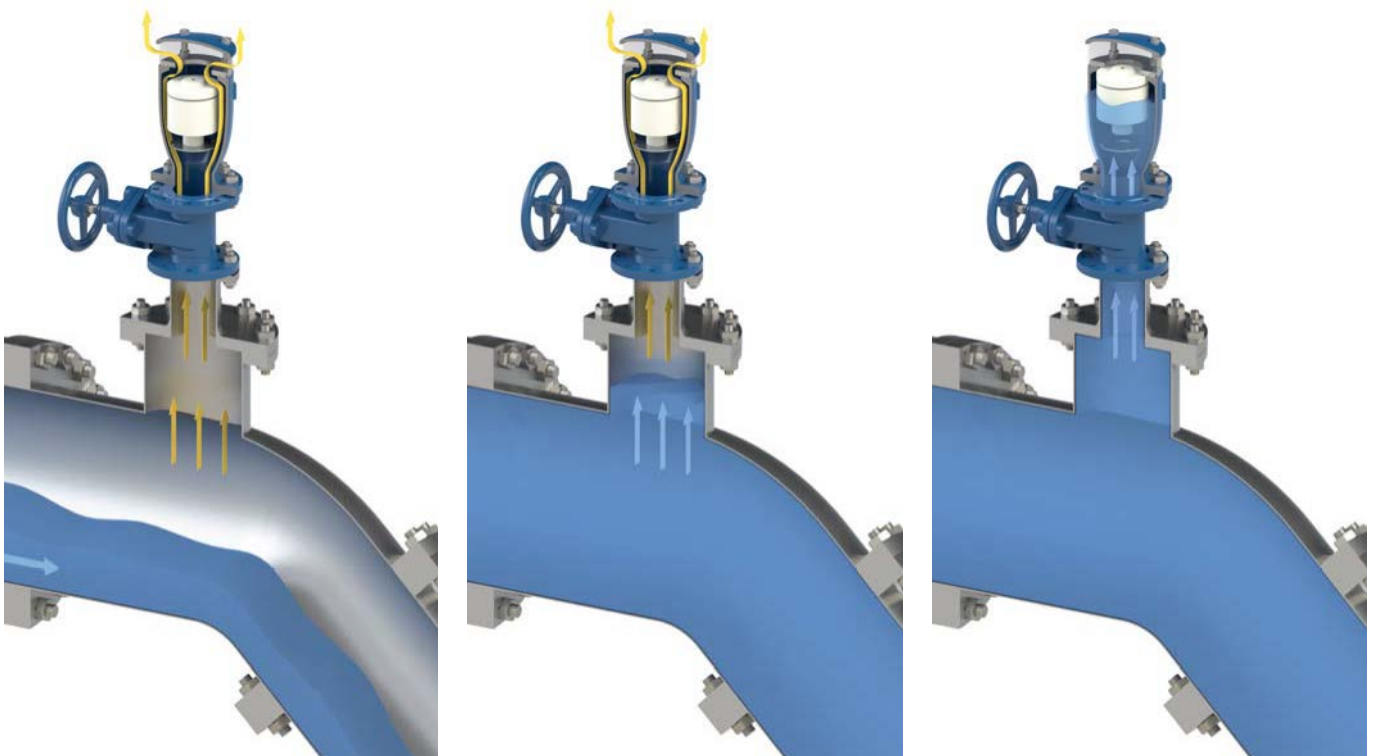

T-T Flow's experience in water hammer prevention of pipeline systems allows us to ensure that we are providing our customers with both the right products and knowledge required for their applications.

The results of ongoing research shows that in general standard air vacuum and combination air valves may lead to problems as rapid closures cannot be avoided or anticipated, we therefore need "smart" air valves able to trigger a protection mechanism to prevent problems from happening and that can be used everywhere without any downsides.

Two solutions have been designed, these are RFP and AS technology. RFP stands for rapid filling preventer and AS for anti-slam. They are both devised for surge protection and are available with 2 functions (2F) or three functions (3F) and their variations, to meet the most demanding and severe installation requirements.

**RFP technology**

RFP technology can be considered like some sort of air bag for pipelines and is based on ensuring unrestricted flow of air in during vacuum. This provides the same degree of protection of a standard air valve during critical operations like pipe draining, burst of pump failure with the forth functions or RFP mechanism being triggered only in case of excessive air out flow, to prevent the valve from being slammed shut from water during the closing phase.

RFP can be used everywhere except for those sections of the pipe where column separation may occur and exposed to severe negative pressure conditions.

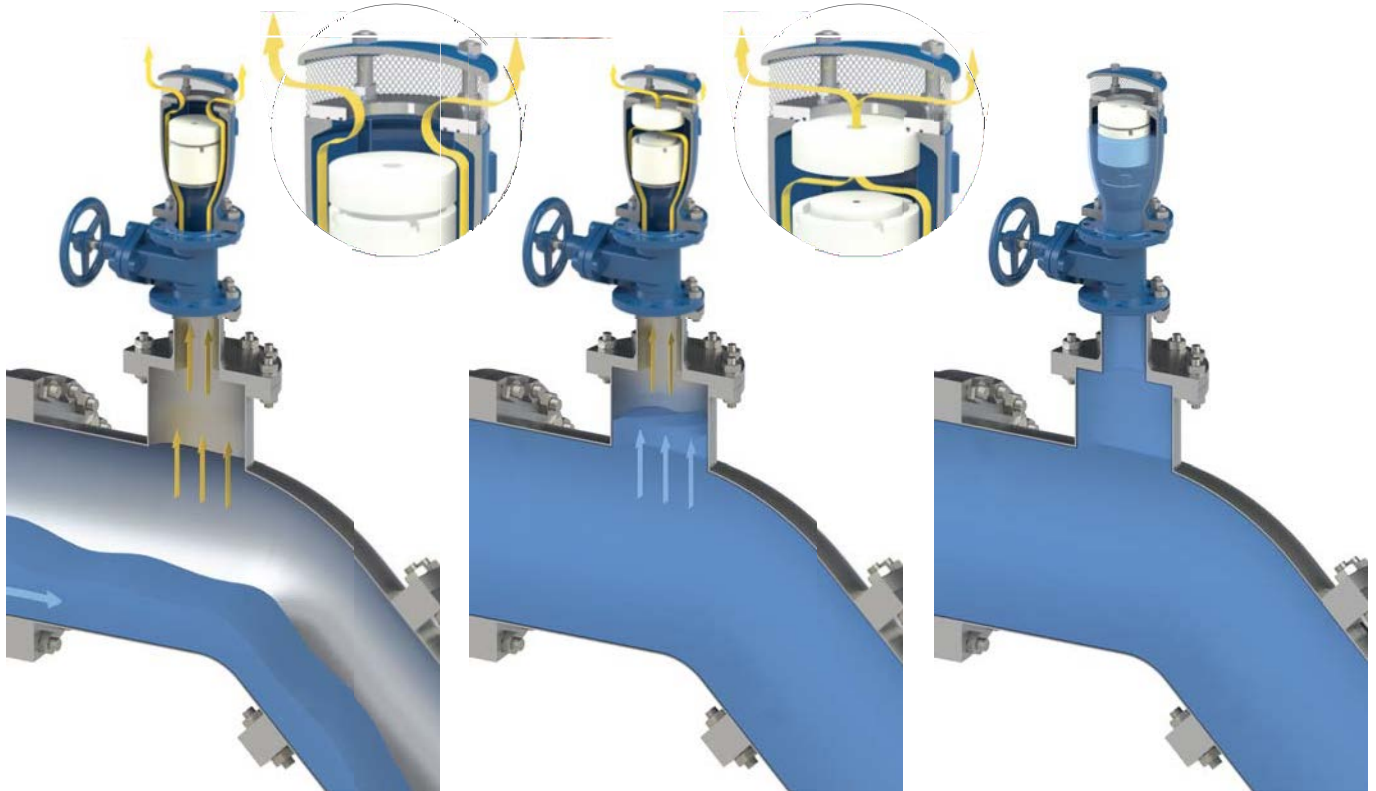

The below graphs show the particular pressure measurements taken on a pipeline subject to rapid filling with frequent failures due to the water hammer generated by conventional combination air valves. These are depicted in dark blue, with the T-T Flow 3F RFP in light blue which is necessary to solve the problem.

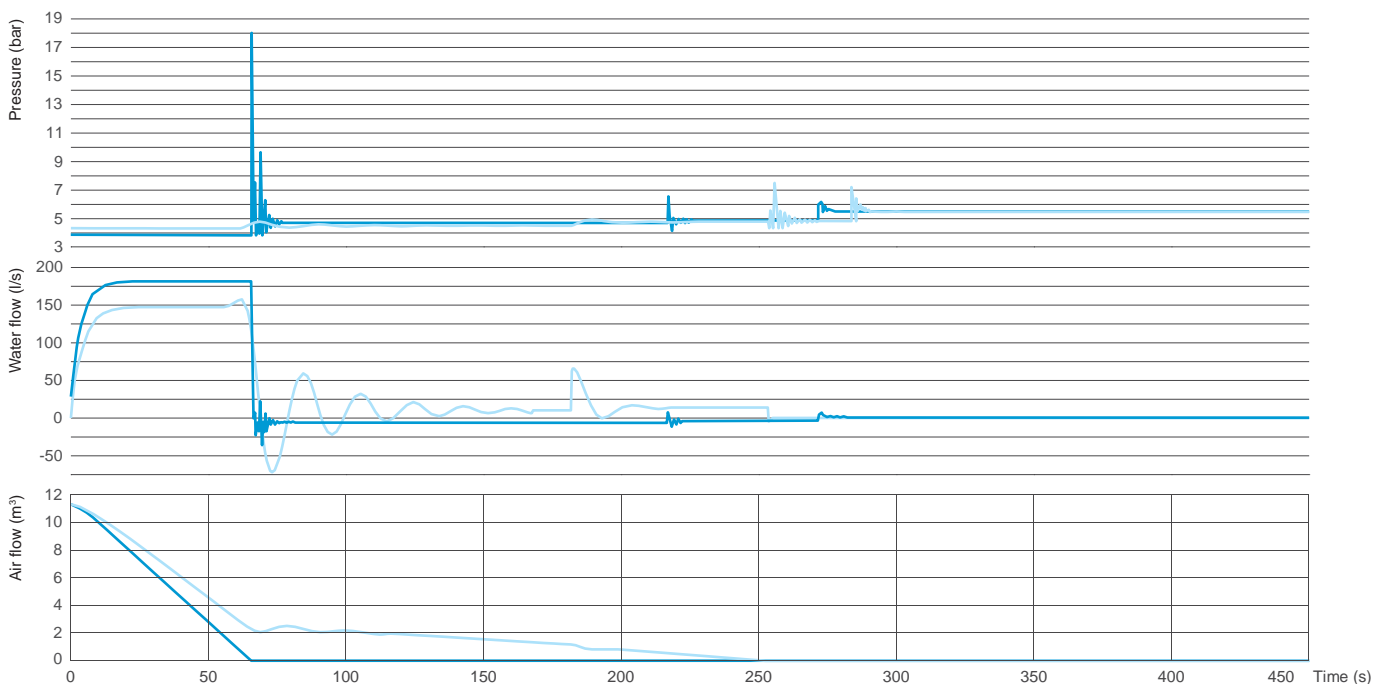

**Aquabrake 3F RFP**

Here are the most important technical features of the T-T Flow water combination non slam air valve, Aquabrake 3F RFP.

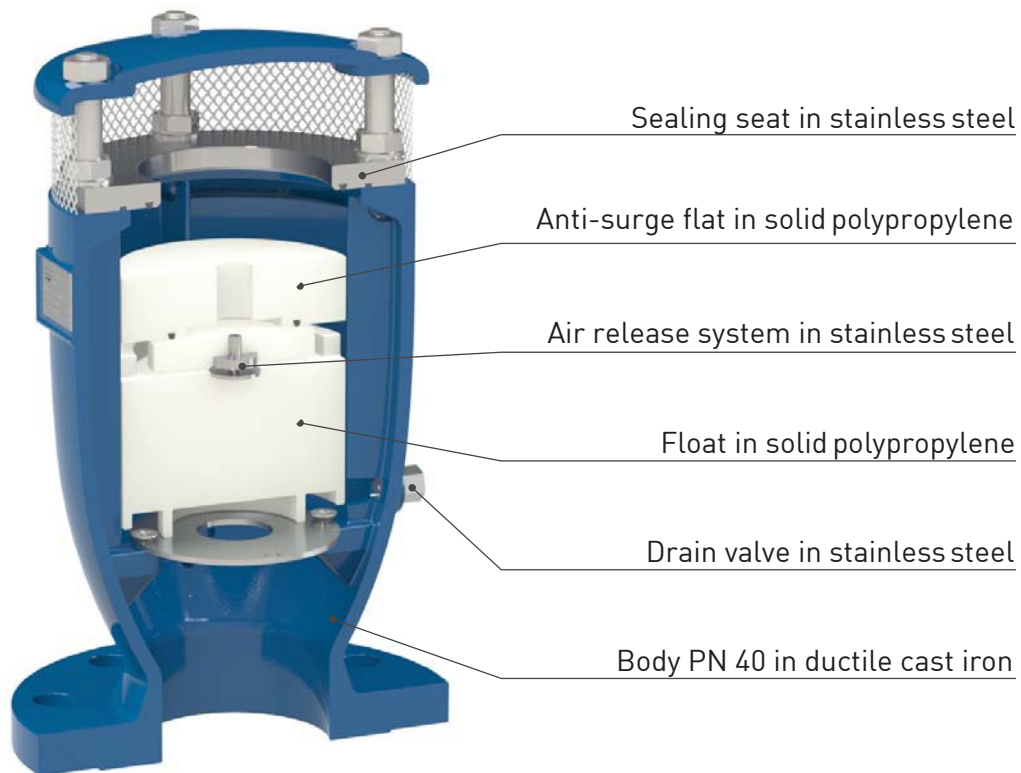

**Fig 4000 RFP**

Here are the most important technical features of the T-T Flow wastewater combination non slam air valve Fig 4000 RFP.

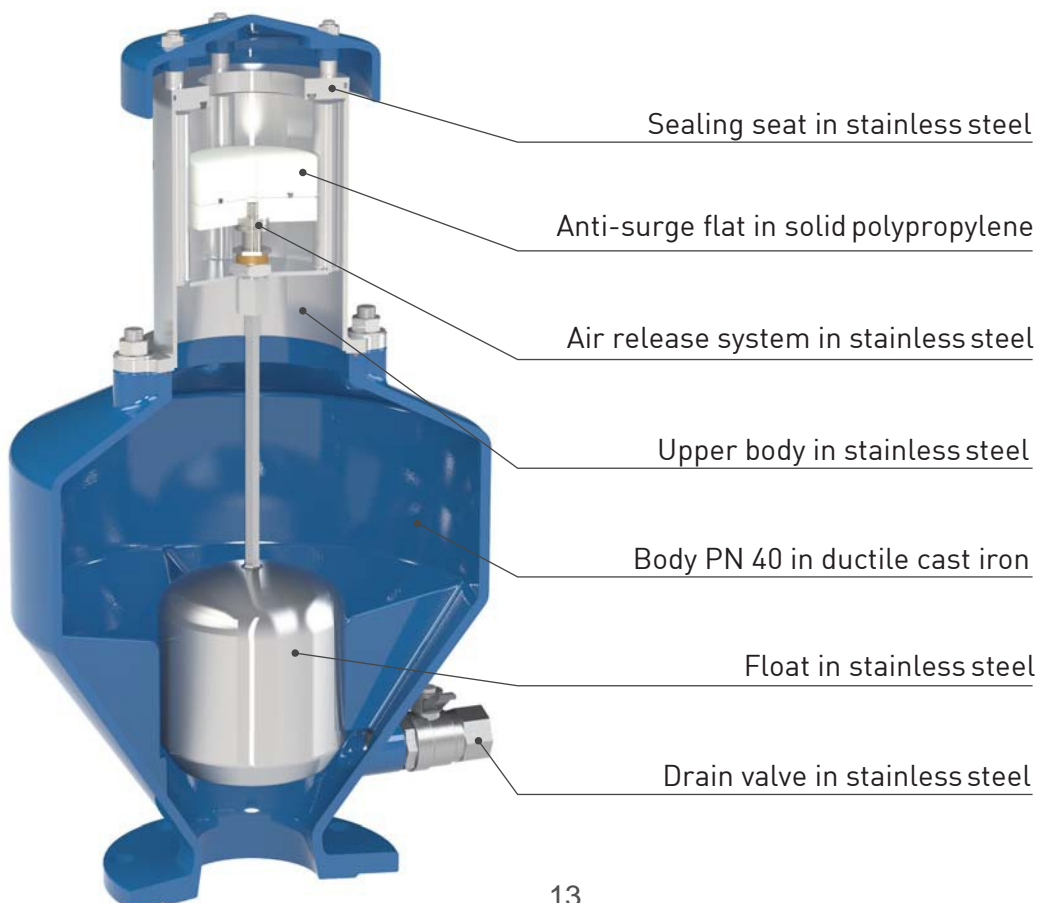

## AS technology

AS technology, is obtained by an automatism composed of a metallic disk, spring and shaft, and located on top of T-T Flow air valves, therefore never in contact with the liquid thus maintenance free. As soon as negative pressure conditions occur the disk is pulled down and air will enter through the main orifice unrestricted. Upon termination of the negative pressure phase the spring will pull up the flat, allowing air outflow through adjustable orifices and creating the anti-surge protection with the effect of reducing the water column approach and acceleration towards the air valve. The anti-slam or anti-shock technology is definitely the safer choice under many circumstances.

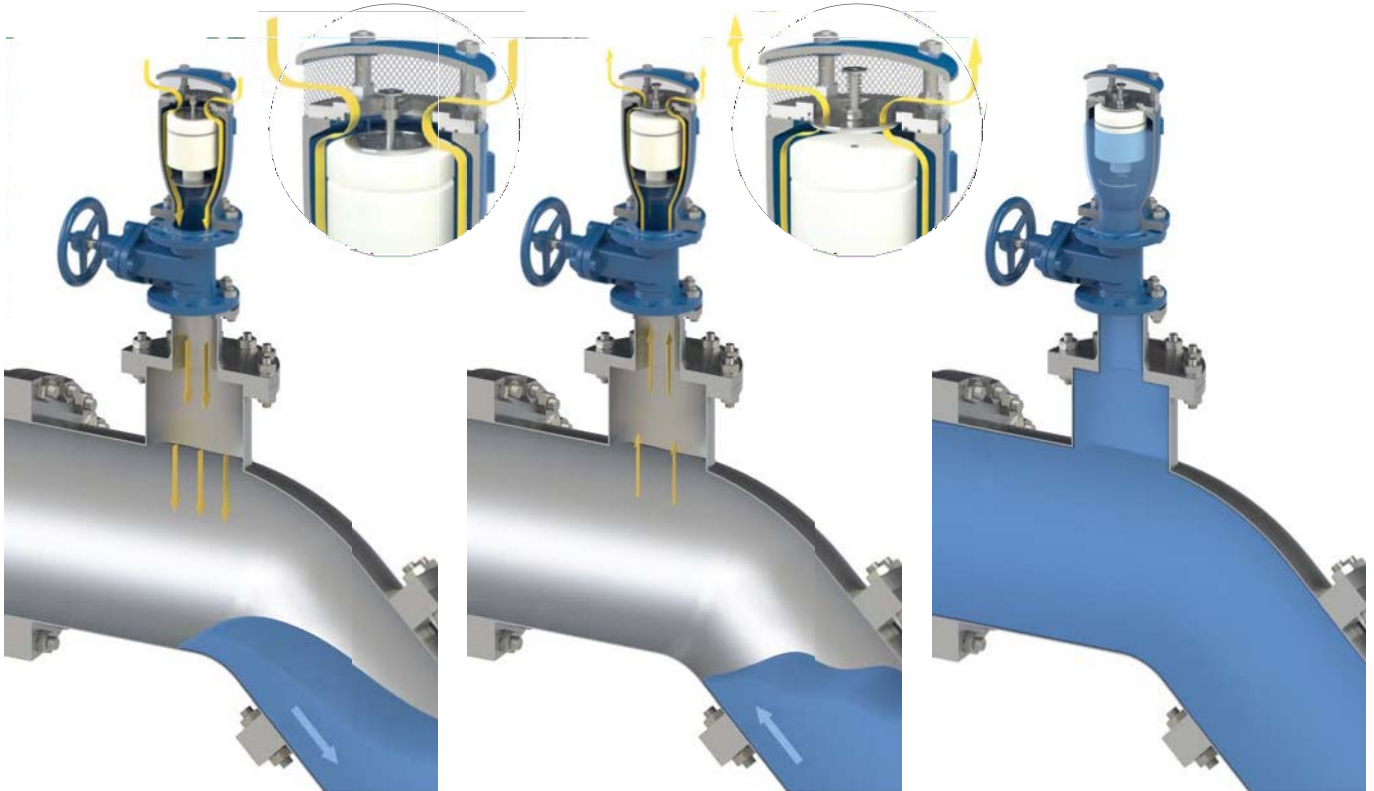

The below graphs show the particular pressure measurements taken on a pipeline subject to frequent pipe failures due to the water hammer generated by pump cycles. These are depicted in dark blue, with the T-T Flow 3F AS in light blue which is necessary to solve the problem.

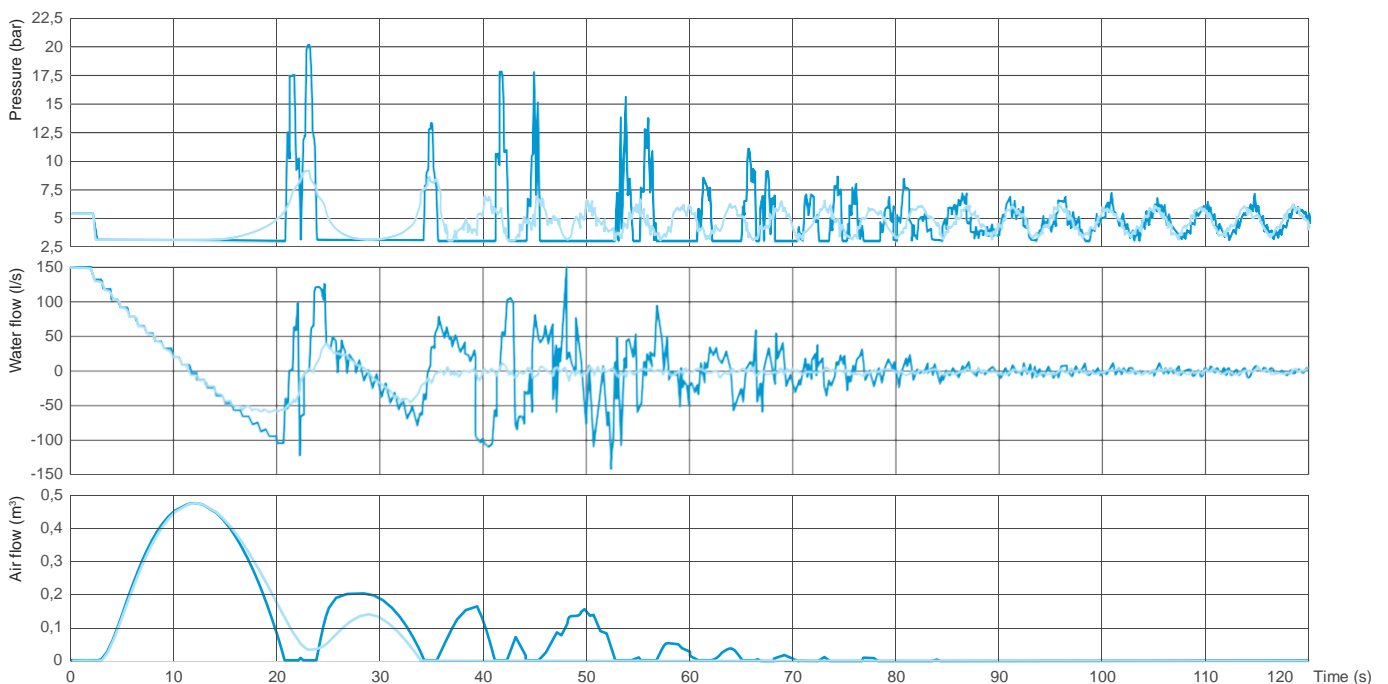

**Aquabrake 3F AS**

The most important technical features of the T-T Flow water combination anti-slam air valve Aquabrake 3F AS.

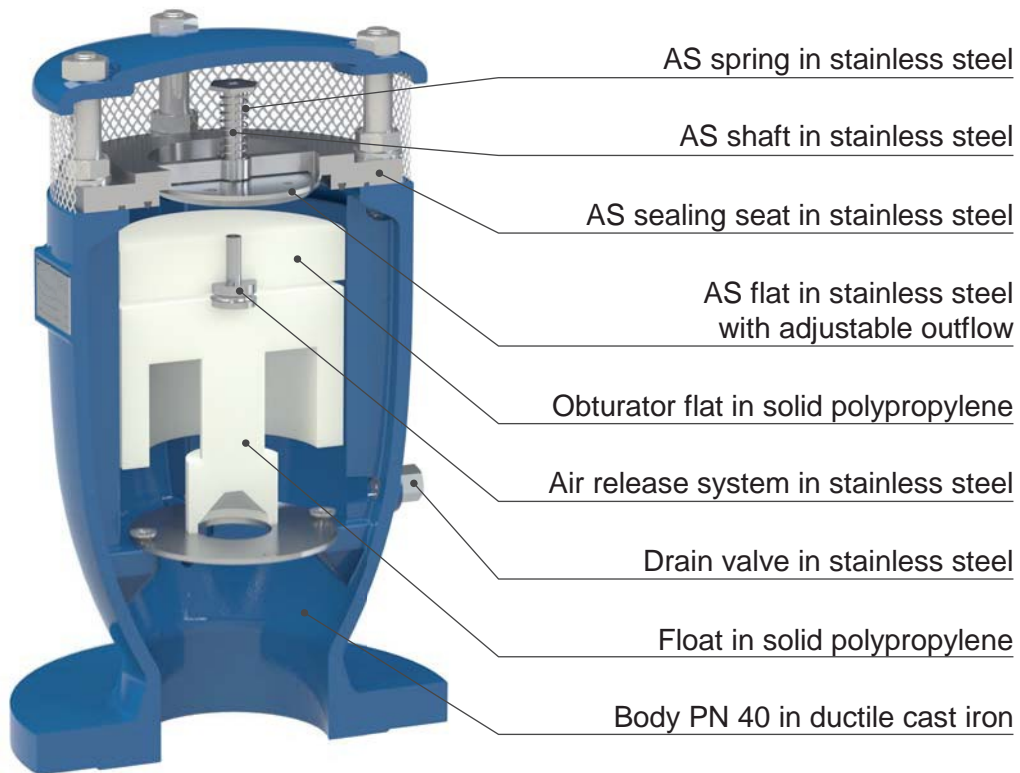

**Fig 4000 AS**

The most important technical features of the T-T Flow wastewater combination non slam air valve Fig 4000 AS.

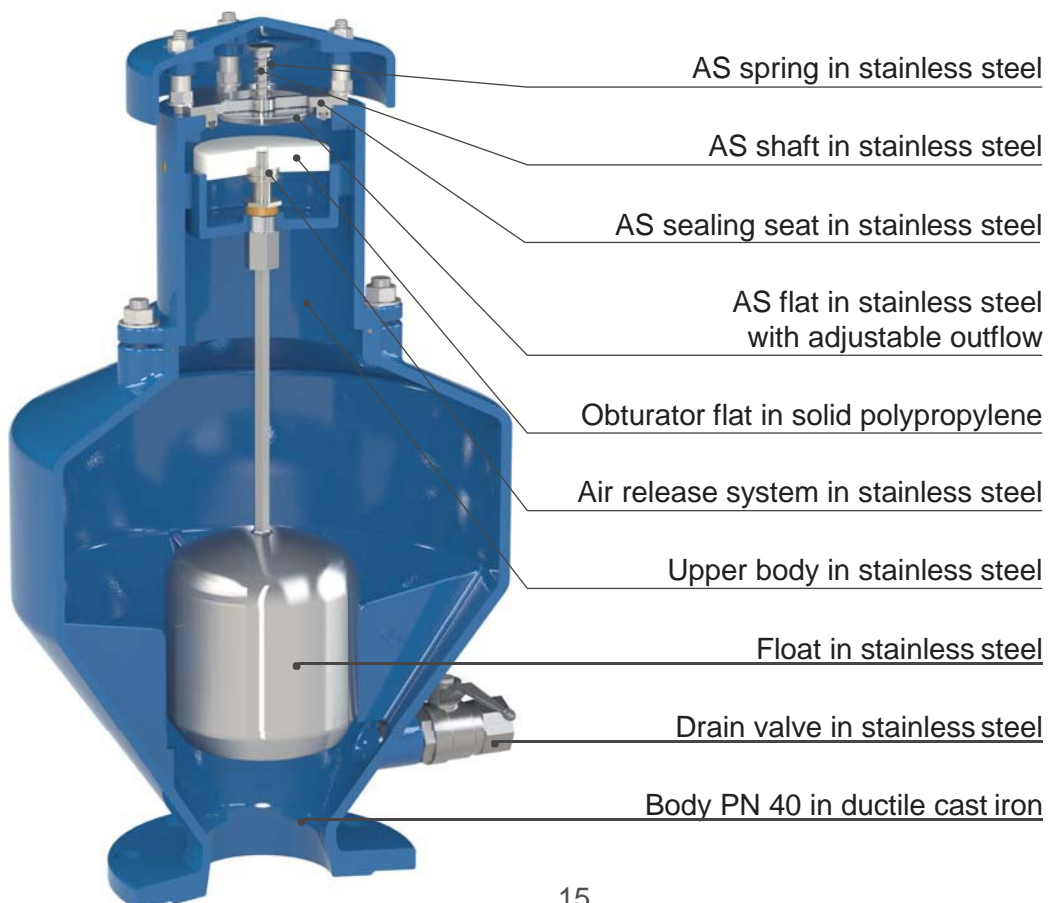

### Applications of AS air valves for water works

AS air valves are usually installed near pumps exposed to negative pressure in case of power failure. Thanks to their performance they will allow the entrance of large volumes of air, avoiding negative pressure conditions on the system to contain upsurges during the second phase, by means of the anti-slam system with adjustable outflow.

The picture below shows the T-T Flow 3F AS anti-water hammer combination air valves located at the outlet of vertical pumps before the check valve, with the SUB air conveyance system, and at the outlet for air release and surge prevention.



AS air valves are needed in presence of sectioning and/or modulating devices, usually installed upstream and downstream of them, both to protect the system during filling and set up operations and to prevent negative pressure during closures and interruption of the flow.

The picture below shows an installation on a dead end in combination with a self-flushing pilot operated control valve. The surge prevention system on the air valve when filling the pipeline is extremely important to avoid and prevent unwanted surge.





### Applications of AS air valves for wastewater

AS air valves are usually installed near pumps exposed to negative pressure in case of power failure. Thanks to their performance they will allow the entrance of large volume of air avoiding negative pressure conditions on the system to contain upsurges during the second phase, by means of the anti-slam system with adjustable outflow. The picture below shows the T-T Flow 2" compact anti water hammer combination air valves located at the outlet of the submersible pumps before the check valve, and at the outlet for air release and surge prevention in combination with the innovative surge tank, which doesn't require any bladder or compressor.



AS air valves are needed in presence of sectioning and/or modulating devices, usually installed upstream and downstream of them, both to protect the system during filling and set up operations and to prevent negative pressure during closures and interruption of the flow. The picture below shows the anti-water hammer combination air valves located on the changes in slope of a riser of a wastewater distribution system, with connections provided with check valves and isolation devices.



## Application and sizing of air valves

The proper sizing of air valves is carried out using specific software or through manual calculations, which involve three steps and requires the pipeline profile with chainage and elevation of each point. The most important function of an air valve is to release air pockets out of the pipeline and to avoid negative pressure conditions.

### 1-Accumulation of air pockets

The first step is to identify the locations where air pockets are likely to accumulate in working conditions like high points, changes in slope descending, long descents e sub-horizontal segments especially if subject to variation in flow reaching values below of the critical velocity, necessary for the hydraulic air removal. When installing air valves on location exposed to the gathering of air pockets it is advisable to create some sort of air trap also called accumulation chamber between the air valve and the pipeline. The pictures shows this concept with some indication in terms of size of this chamber user can follow as a rule of thumb, without exceeding a certain size in terms of DN to prevent vortex and turbulence from forming thus producing the opposite effect and affecting the proper airrelease.

High points



Change in slope descending



Long descending, sub-horizontal segments



Size of the accumulation chamber

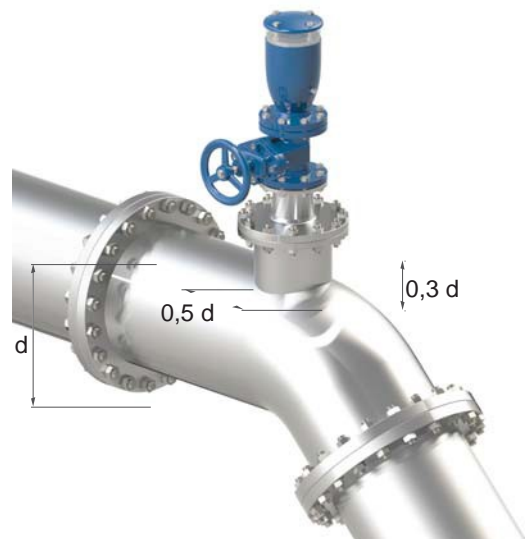

## 2-Pipe burst analysis

The second step is to simulate pipe burst along the profile, in general on the lower parts of the profiles and at those locations considered to be critical if exposed to such unfortunate event, calculating the amount of water discharged. The same amount of air through the air valve during the intake, within allowable DP, will then have to be guaranteed for the proper protection of the system against negative pressure condition.

With regard to that the formula to be used is the following, where DB is the diameter whose section has been obtained according to a burst % depending on the material, S is the slope, CR is the roughness coefficient and K is a dimensionless coefficient.

$$Q_B = K \cdot C \cdot D_B^{2,63} \cdot S^{0,54}$$

The picture is showing the pipe burst, expressed in terms of section ( $A_{burst}$ ) as a percentage of the pipe area ( $A_{pipe}$ ). We always recommend to include a safety factor ranging from 1.5 to 3 depending on the material, soil, installation criteria and years of the pipeline. GRP, cement and thin pipeline in stainless steel will be more critical than DI for example.

Below the chart expressing the average pipe burst values for the most common pipe materials.

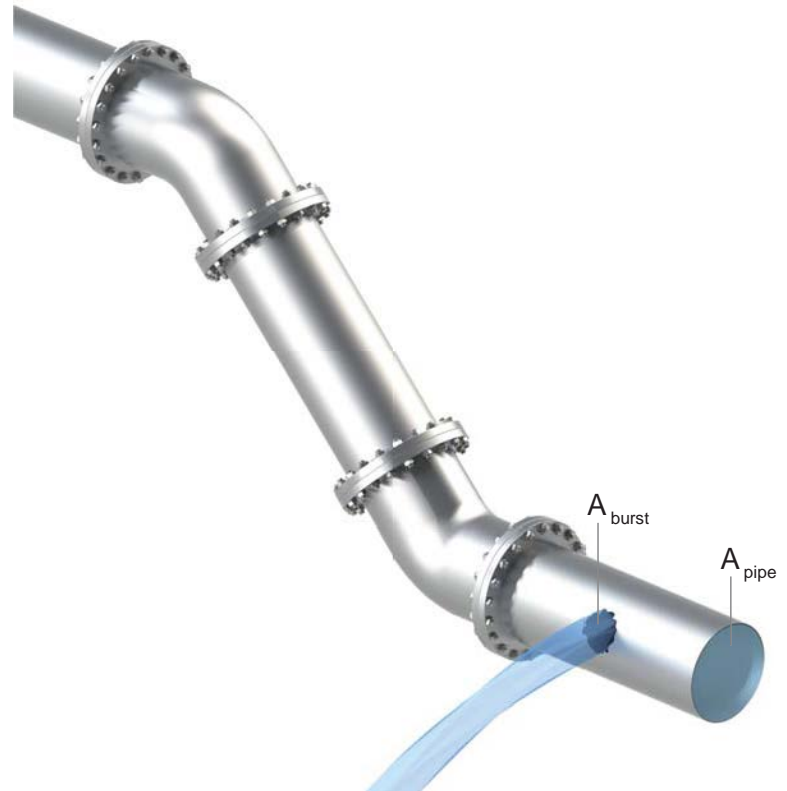

Pipe material	Average burst %
HDPE	20-25
GRP	32-38
Cement	45-55
Ductile cast iron	15-20
Cast iron	22-30
PVC	14-18
Steel	14-18

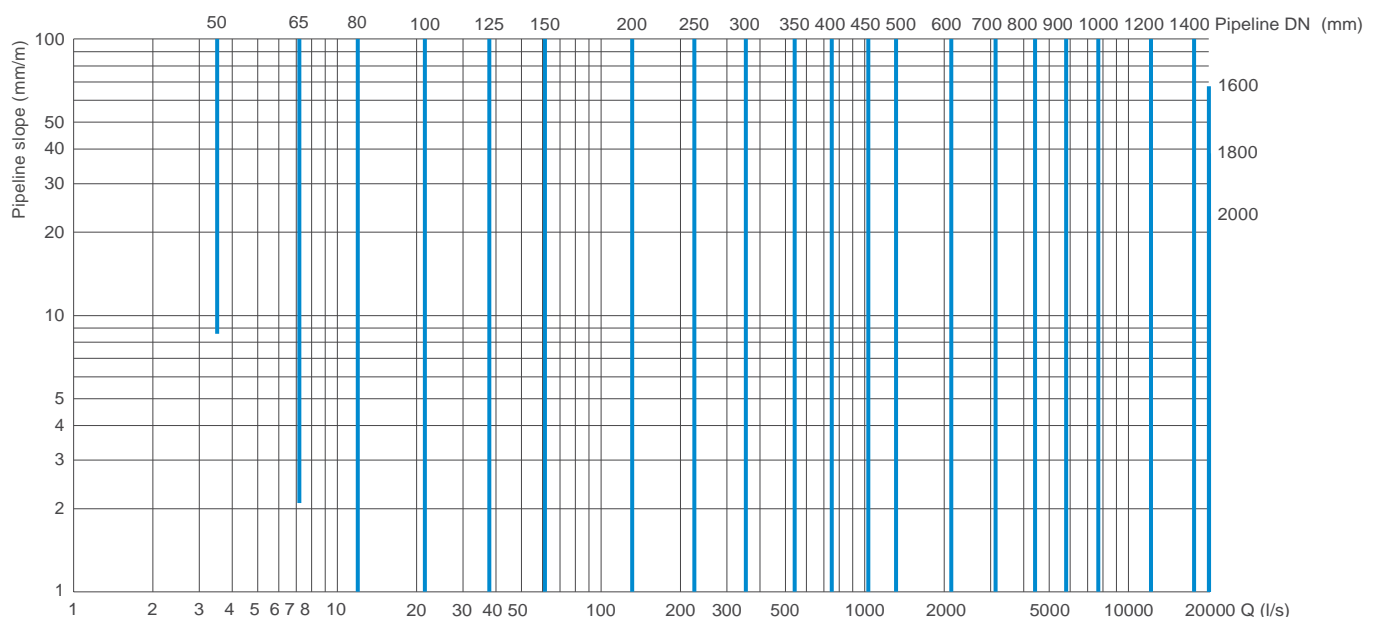

The chart above is an indication to show the amount of water discharged in case of steel pipes versus slope, assuming a burst percentage of 100, which is highly conservative.

During the pipe burst analysis, software performs a thorough analysis of the entire profile identifying the critical locations and locating automatically the air valves for high points, changes in slope ascending, descending long segments and sub-horizontal lines, then sized to cope with the most conservative scenario. Finally in presence of long and sub horizontal segments air valves shall be placed equally distanced with a spacing ranging between 400 and 800 meters depending on the application, pipeline and evaluation of transient phenomena.

**High point**

$Q_1$  and  $Q_2$  are calculated, the higher value is then taken for the analysis.

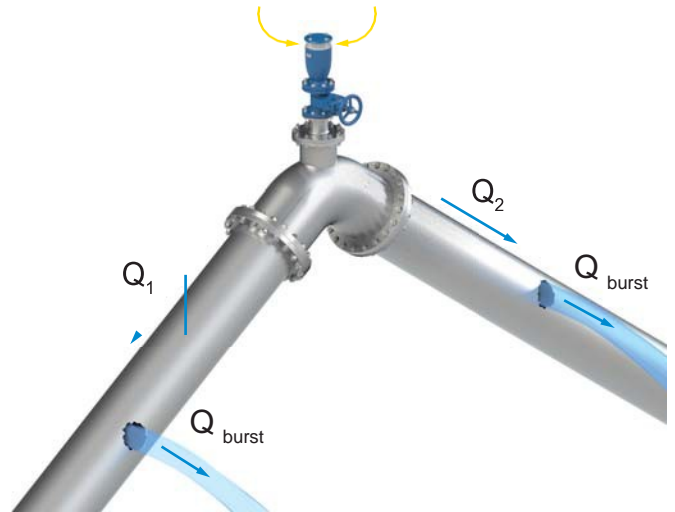

**Change in slope descending**

$Q_1$  and  $Q_2$  are calculated, the difference is obtained for the analysis

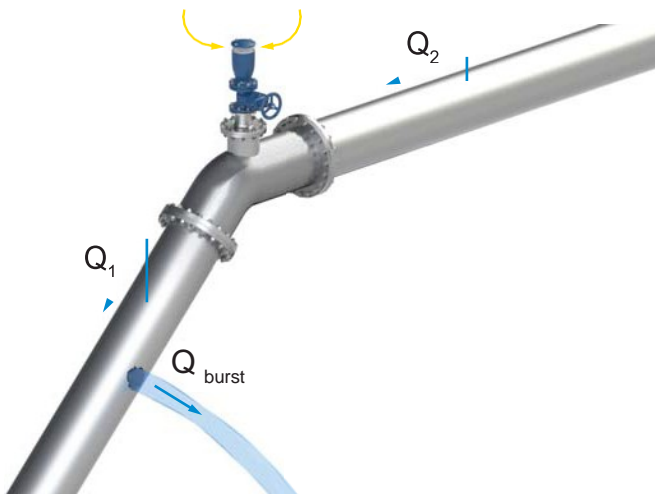

**Change in slope ascending**

$Q_1$  and  $Q_2$  are calculated, the difference is obtained for the analysis

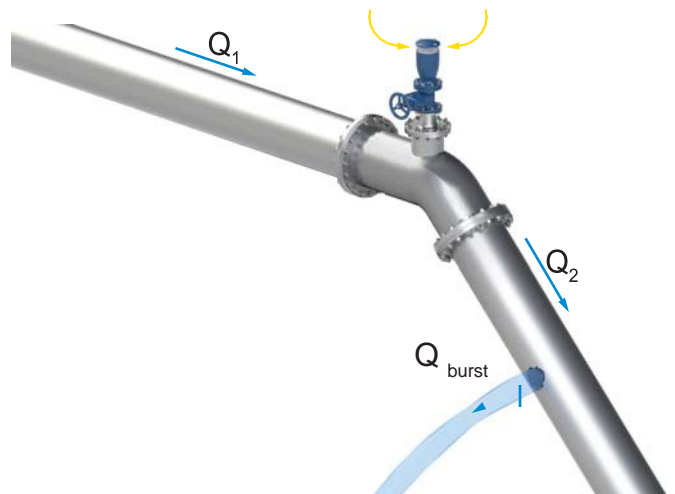

**Long descends, ascends, sub-horizontal segments**

$Q_1$  and  $Q_2$  are calculated and used with air valves spacing ranging between 400 and 800 m

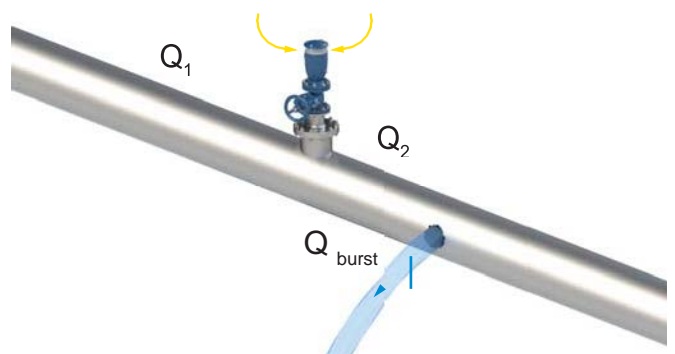
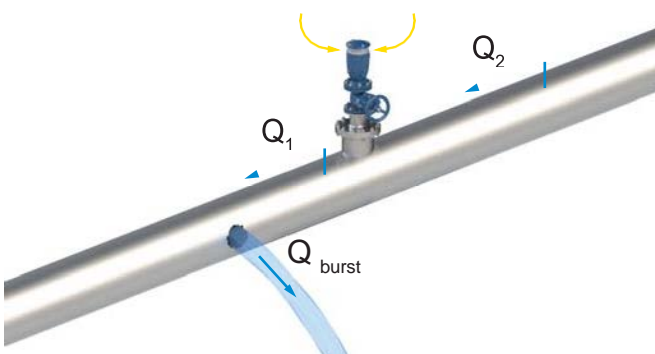

### 3-Pipe drainage analysis

The third step is to simulate the draining phases by opening the drain valves where present and assessing the amount of water flowing out. With regard to that the formula to be used is the following, where  $D_d$  is the DN of the gate valve,  $Lh$  is the difference in pressure acting between the air valve and the drain,  $C_d$  is the discharge coefficient ranging between 0,5 and 0,7 depending on the piping between the main transmission line and the gate valve, difference in DN, kind of sectioning device. For common installation a value of 0,61 is recommended.

$$Q_d = C_d \cdot \left( \frac{\pi \cdot D_d^2}{4} \right) \cdot (2 \cdot g \cdot Lh)^{0,5}$$

During the pipe drainage analysis the software methodology is the same, the main difference though is that the study is carried out only of those segments involved in negative pressure as a consequence of the opening of drains, which shall be specified by the customer in terms of DN and discharge coefficient. As an instance peaks and critical locations won't be examined if drains are not identified and created in the model. We always recommend including a safety factor in this case ranging from 1.5 to 2 depending on the status of the drains, years of the pipeline and maintenance issues.

Software has been developed with a friendly windows interface and is able to simulate air valves location and sizing, in addition to steady state hydraulic analysis of profile. This is used to determine head loss, HGL and the behaviour of regulating devices and boundary conditions such as tanks, pumps, control valves, modulating devices, consumption and much more. Pipeline properties and mechanical properties are also taken into account for the analysis providing a preliminary indication of the collapsing value. The software uses many editor windows where users can input and calculate the profile with all the parameters and sizing methodology mentioned in this manual; allowable negative pressure, pipe burst and drain, air valves spacing are clearly identified.



The software also includes specific algorithms: the first able to consider air valves refinement, when many changes in slopes occur in short segments and some of them are skipped due to project and installation requirements. The second takes into account the air valves reaction time during the opening phase and their behavior in presence of possible conditions likely to produce surges. For example, rapid filling. The air valves sizing software is seamlessly integrated with the dynamic program for water hammer and transient analysis.

## Allowable negative pressure

The main purpose of an air valve is to enter a volume of air equal to the amount of water discharge through steps 1 and 2 namely pipe burst and drainage analysis, producing a negative pressure value acceptable for the case study and depending on the pipe material, thickness, ID. If we discharge water of the main without replacing it by air entrance through the air valves we will inevitably experience negative pressure. Many problems are associated with this event like pipe deformation, possible collapse, movement of gaskets, entrance of contaminated water and pollution through segment of the pipe exposed to leakage.

As an indication the maximum allowable pressure to be used the following formula is shown below where C is a safety factor usually 2,

$$P_c = \frac{20 \cdot E \cdot (t/D)^3}{(1 - \mu^2) \cdot C}$$

Where  $P_c$  is the collapsing pressure (bar),

20 is a proportionality constant,

E is the modulus of elasticity (mPa),

$\mu$  is the Poisson's ratio (0,4 for plastic),

t is the pipewall thickness (mm),

D is the pipe outside diameter (mm),

C is the safety factor (2 for negative pressure).



For plastic pipe the pressure resistance versus temperature must also be taken into account as well as the material's decay if exposed to frequent negative pressure fluctuations.

The concept air flow capacity is important for the proper analysis and air valves assessment, especially during the intake, as an example, below is a particular of air performance chart for T-T Flow Aquabrace combination anti hammer AS air valves full bore series.

The three zones depicted on the chart are based upon T-T Flow advice about how to use air valves with regards to the allowable differential pressure. The pipe tolerance to negative pressure should always be confirmed through static analysis and information provided by the pipe supplier, as general guideline we can identify them into A/B/C:

A: recommended working condition with a maximum allowable negative of 0,1 bar

B: working conditions with DI pipes with a maximum allowable negative of 0,2 bar

C: damage working conditions with risk of pipe deformation, collapse. A negative pressure higher than 0,2 bar should never be exceeded

### AIR ENTRANCE DURING PIPE DRAINING

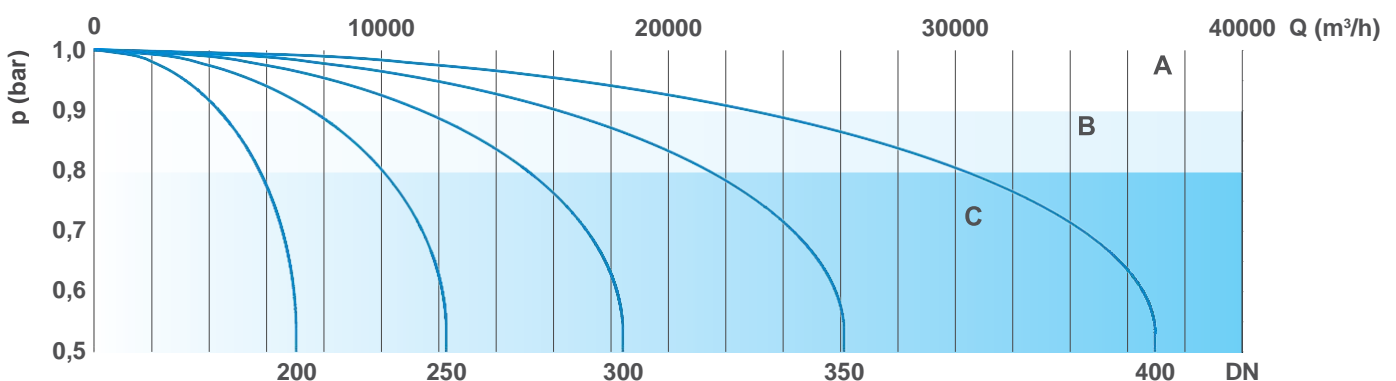

## Air valves location

The picture below indicates the positioning and location of air valves on a pumping mains, applicable for water and wastewater use, with the selection between T-T Flow combination anti surge air valves RFP and AS series according to the profile and propagation of the pressure wave in case of transient event, in this case represented by a sudden power failure. For long horizontal segments of the pipeline, between the air valves and the changes in slope, a simple air release model is advised.

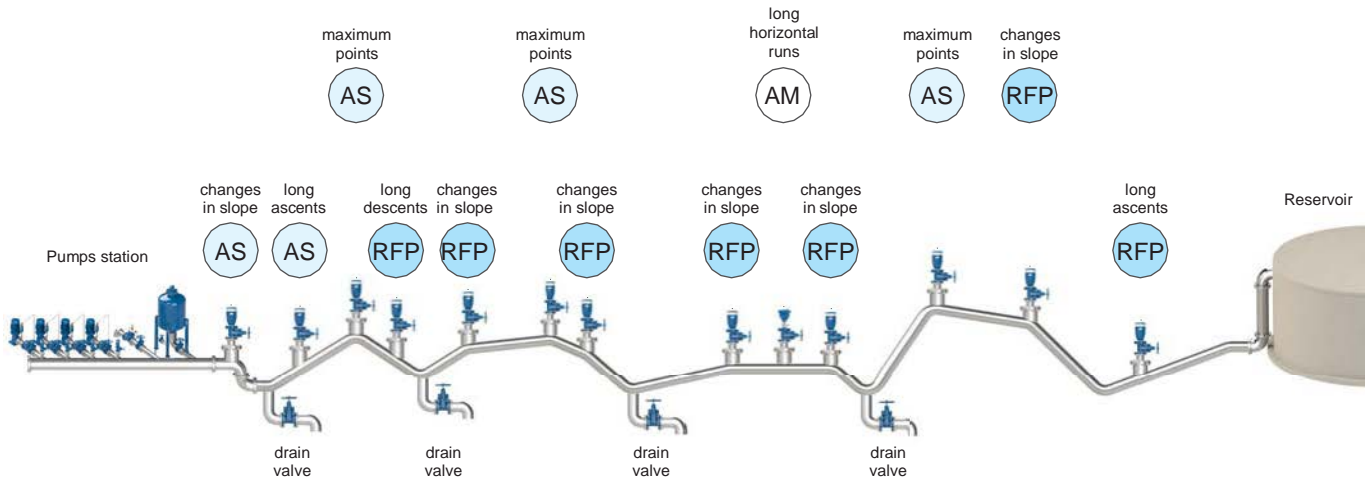

- AM** Automatic air release valve – Aquabreak Mini
- AS** Anti-shock combination air valve
- RFP** Rapid filling prevention combination air valve

The picture below indicates the positioning and location of air valves on a gravity fed pipeline, applicable for water and wastewater use, with the selection between T-T Flow combination anti surge air valves RFP and AS series according to the profile and protection against possible transient events, in this case represented by sudden pipe filling and rapid flow variation caused for example by the level regulation device located down- stream.

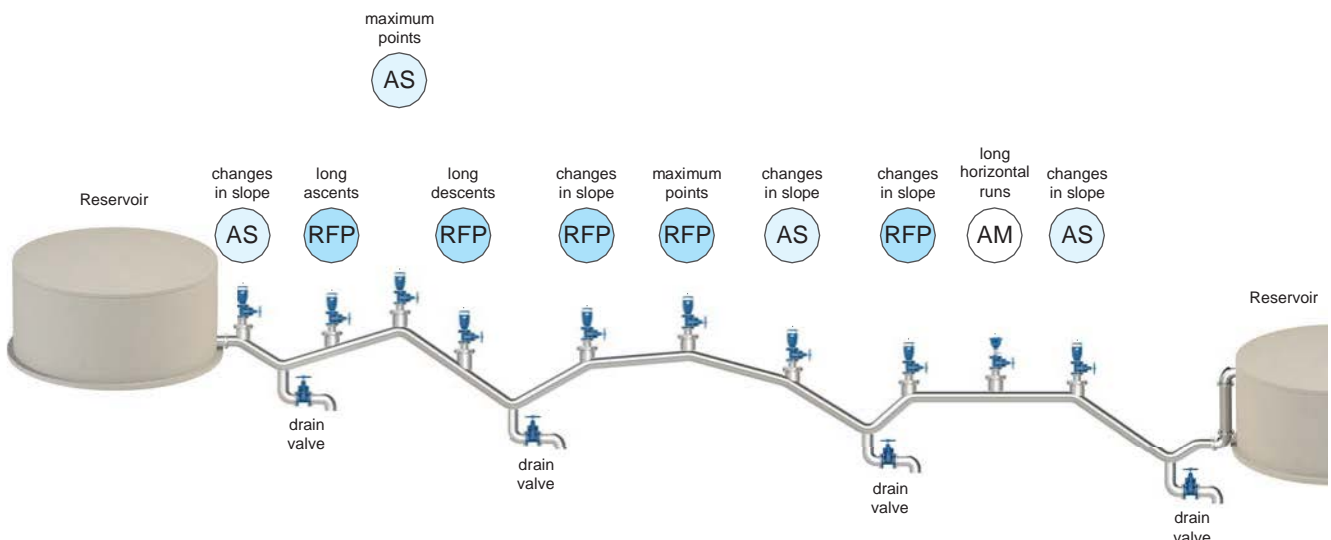

**Installation - Water air valve with accumulation chamber**



**Installation - Wastewater air valve with accumulation chamber and air conveyance system**







### Testing facilities

T-T Flow offers in-house calibrated, hydrostatic and electrical testing facilities to ensure that our valves are rigorously tried and tested before they leave the door. Furthermore, prior to leaving the company each product undergoes a comprehensive inspection ensuring that only the highest quality products arrive on site. With our fully equipped machine assembly shop we are able to provide complete and bespoke solutions to fit any application. Quality is given to the highest priority and the company has a continual program of improvement, with approval of its quality management systems to ISO9001.

Striving to meet the highest standards T-T Flow has a range of products that have WRAS (Water Regulations Advisory Scheme) approval. To achieve this accreditation, T-T Flow products must comply with the stringent third party evaluation process encompassing mechanical assessments and material examinations to demonstrate that the valves are not detrimental to water quality.

Aside from our testing facilities you can rely on T-T Flow to provide comprehensive after-sales support. We will also provide you with any supporting documentation, certification and CAD drawings you require. We also have a team of dedicated engineers that will provide technical advice every step of the way.

