

# VASCO



# Pressurisation with VASCO



Industry



Commercial



Domestic



# Variable Speed Controller

## VASCO

is a purpose-built family of variable frequency drives, designed to **control** and **protect** pumping systems based on changing pump speed.

From water supply for domestic, irrigation, commercial and industrial applications, to heating, ventilating and air conditioning, from filtering to pressure-washing, the VASCO range perfectly fits any new or existing application ensuring:

- **energy and cost saving**
- **simplified installation**
- **longevity of pumping system**
- **greater reliability**

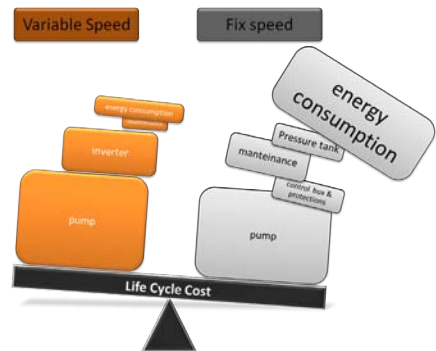

VASCO units are extremely compact and, connected to **any pump on the market** will manage the operation of the pump to **maintain a constant desired physical property** (such as pressure, flow temperature or other). The pumping system runs only at the speed necessary to meet user's requirements, ensuring energy savings and extending the life of the system.

VASCO also provides motor protection and monitoring, such as:

- **protection against overload and dry running**
- integrated **soft start** and **soft stop** functions, extending the life of the system and reducing peak absorption
- indication of **input current** and **supply voltage**
- **recording running hours** and logging errors and alarms reported by the system
- VASCO can **control a second or third pump at constant speed DOL** (DOL: Direct On Line)
- **connect to other VASCOs** to get combined operation

Body is constructed entirely of **aluminium**, making VASCO, with its **compact dimensions**, extremely **solid**, **lightweight** and **easily cooled**, adding to the unit's **versatility**.

IP55 protection makes it possible to install VASCO virtually anywhere, including humid and dusty environments; the **liquid crystal illuminated display** ensures VASCO is easy to operate and a **buzzer** provides an immediate indication of alarm. A **volt free contact** for alarm purposes is also provided.



# Quick installation

VASCO can be installed directly on the cooling fan cover of the motor or directly to the wall using the required installation kit.

## Motor kit

VASCO is cooled by the motor cooling fan.

Motor kits consists of 4 special clamps to fix the VASCO to the motor fan cover.



## Wall kit

VASCO is cooled by an external cooling fan attached to the inverter radiator.

A special metal bracket is supplied for VASCO to be mounted to the wall.



Installing VASCO is simple and intuitive, consisting of a few quick and easy steps:

- Connect VASCO to **power supply**
- Connect VASCO to **pump**
- Connect VASCO to the **sensor**, located wherever in the piping you want to maintain the desired constant physical dimension (pressure, flow, liquid temperature, ...)
- Set VASCO to configure the pump to the system, and the desired performance

If the water demand changes frequently, it is advisable to share the load using a multiple pump group, resulting in greater reliability and efficiency .

## 1 VASCO + 1 or 2 Direct On Line Pumps (DOL)

A first way of splitting consists of installing one pump driven by the VASCO and 1 or 2 DOL pumps directly connected to the main power (Direct on Line) ; VASCO switches on/off the 1 or 2 DOL pumps through contactors.

VASCO alternates the two DOL pumps (same working time) to average out pump wear.

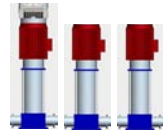

## From 1 to 8 VASCO in COMBO connection

A second way of splitting (named COMBO) consists of using several pumps in parallel (up to 8) each one driven by a VASCO unit.

In this way, efficiency and the reliability of the pump group is maximised; Vasco controls and protects each connected pump.

Each VASCO controls and protects it's pump and the operation is shared among all the connected pumps to average out pump wear; in case of failure, the remaining pumps will maintain the pumping operation.

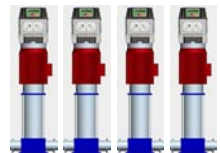

## From 1 to 8 VASCO in COMBO connection + 1 or 2 DOL

Additionally, it is possible to equip the system with pumps connected in COMBO mode plus 1 or 2 DOL pumps to satisfy additional water demand.

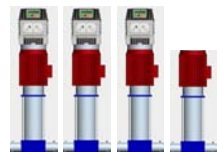

# Set-up

When first powering the VASCO, a quick initial configuration is required for complete configuration of the drive.

Additional parameters can be configured later by entering three different settings levels:

- **End user level.** The only level which can be accessed without password. It allows the user to monitor electrical and hydraulic parameters and status of the VASCO and pump.
- **Installer level.** In this level, the installer can configure the VASCO system to the characteristics of the pump. An entry password is required.
- **Advanced level.** This level allows the electrical configuration of VASCO to the pump. Another entry password is required.

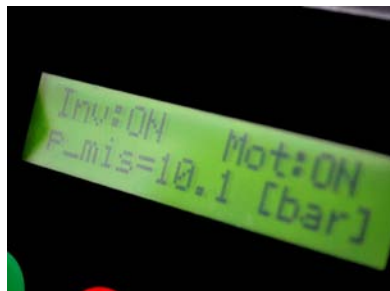

## Constant pressure control

VASCO controls the pump speed to maintain constant pressure at a set point independent of the water demand in the system.

In a hydraulic system equipped with VASCO, the standard pressure tank is replaced by a smaller tank which functions to maintain the set pressure in the system when the pump is stopped.

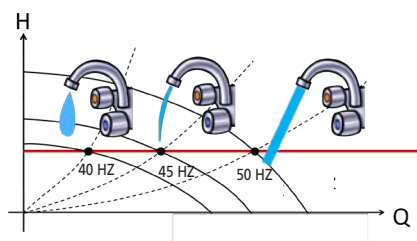
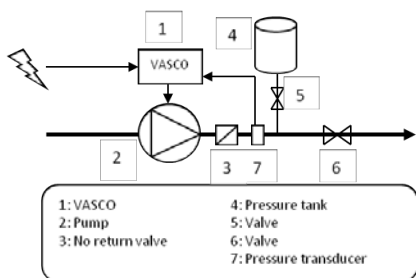

In traditional systems with fixed speed pumps, the larger size of the pressure tank is due to the number of pump starts and to the maximum flow rate of the pump. In large tanks, special precaution has to be taken if the working pressure is high or if there is a possibility of extended stagnation of the water causing bacteria.

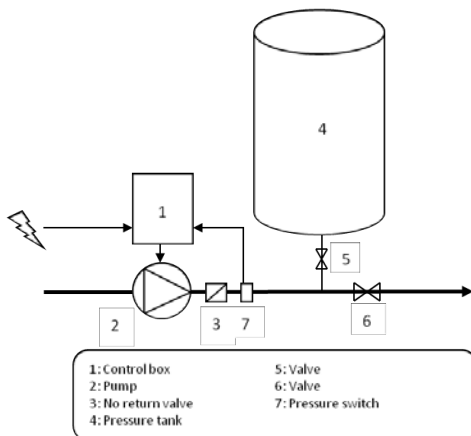

VASCO receives a pressure signal from the pressure transducer and varies pump speed to maintain a constant set pressure regardless of water demand .

# Software made for pumps

Software used in our VASCO drive is the result of many years experience in the field, customer requests and constantly exploring new applications.

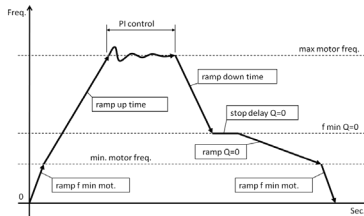

## Minimum motor frequency

This parameter prevents the pump from running below a certain speed, avoiding the risk of damaging the thrust bearing in submersible pumps.

## Minimum motor frequency ramp

To prevent motor damage, the motor can accelerate quickly to reach the minimum motor frequency, and then is allowed to follow a lower start-up ramp.

## Stop function at zero water flow

After reaching the minimum frequency at zero flow (F min Q=0) VASCO progressively slows the pump while monitoring the signal from the pressure transducer. If the pressure is close to the set pressure, VASCO stops the pump.

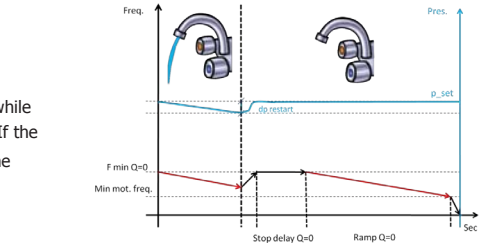
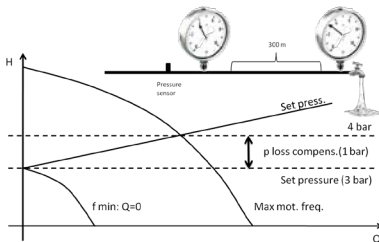

## Dry running signal via cosphi value (Phase Angle)

If the pump runs dry, its cosphi value drops below a settable cosphi value, and VASCO stops the pump after 2 seconds. VASCO will try to start the pump every 10, 20, 40, 80 and 160 minutes, after which it will declare an alarm and stop the pump if the condition persists.

## Maximum and minimum pressure alarm

When the pressure rises above a certain settable pressure value, VASCO will stop the pump to prevent damages to the hydraulic components in the system. Similarly, if the pressure drops below a certain set pressure an alarm is declared and the pump is stopped.

## V/f programmable curve

VASCO has the ability to choose between two different methods of torque control voltage (V) versus pump speed (frequency):

- constant torque (linear V/f)
- quadratic variable torque (squared V/f)

For centrifugal pumps, energy savings can be obtained by selecting squared V/f control.

## Settable carrier frequency between 2.5, 4, 8, 10, 12 kHz

If VASCO controls a submersible pump with a long cable run, it is possible to decrease the carrier frequency value to ensure longer motor life.

## Several control modes available

In addition to constant pressure control, VASCO allows other control modes such as fixed frequency, constant flow, constant temperature.

# Performance

model	Vin +/- 15% [V]	max Vout [V]	I out [A]	Typical motor P2 [kW]
VASCO 209	1 x 230	1 x 230	9	1,1 KW
		3 x 230	7	1.5 KW
VASCO 214	1 x 230	1 x 230	9	1,1 KW
		3 x 230	11	3 KW
VASCO 409	3 x 400	3 x 400	9	4 KW
VASCO 414	3 x 400	3 x 400	14	5,5 KW
VASCO 418	3 x 400	3 x 400	18	7,5 KW
VASCO 425	3 x 400	3 x 400	25	11 KW
VASCO 432	3 x 400	3 x 400	32	15 KW
VASCO 444	3 x 400	3 x 400	44	22 KW

## General characteristics

- Power frequency: 50 - 60 Hz (+/- 2%)
- Max. ambient temperature at nominal current: 40°C (104 °F)
- Max. altitude at nominal current: 1000 m
- Grade of protection: IP55 (NEMA 4)
- Settable digital output signals (N.O or N.C):
  1. Motor run signal
  2. Alarm signal
  3. DOL 1 pump signal
  4. DOL 2 pump signal
- Analog input (10 or 15 Vdc):
  1. 4-20 mA
  2. 4-20 mA
  3. 4-20 mA / 0 - 10 Vdc (settable)
  4. 4-20 mA / 0 - 10 Vdc (settable)
- 4 Digital input , N.O. or N.C (settable) , for motor run and motor stop
- RS485 serial communication

T-T are able to offer a wide range of accessories including pressure sensors, flow sensors, temperature sensors, shielded cables, input EMC/RFI filters, and output dv/dt filters to protect motor windings in presence of long cables.

For more information, contact our Sales staff .

VASCO 209/214/409

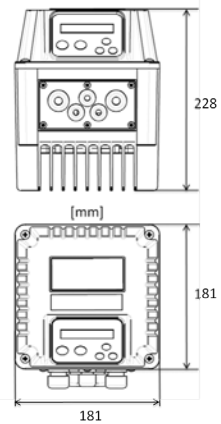

VASCO 414/418/425

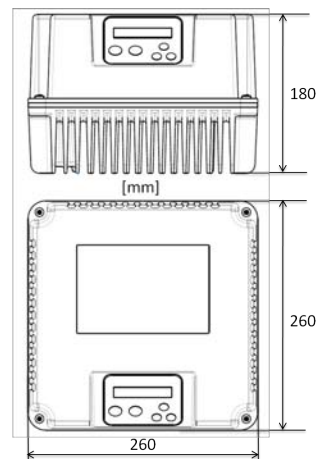



HEAD OFFICE

**T-T PUMPS Ltd., Onneley, Woore, Cheshire CW3 9RU**

SOUTH EAST SERVICE & SALES DEPOT

**Unit 4b, Wilstead Industrial Park, Wilstead, Bedford, MK45 3PD**

**Tel: 01630 647200 Fax: 01630 642100**

**www.ttpumps.com e-mail: response@ttpumps.com**

**T-T PUMPS® T-T Projects T-T Controls T-T Enviro T-T Service** 

We reserve the right to amend specifications without prior notice. © T-T PUMPS Ltd.